

# Luca Abate

## Bachelor of Design (Industrial Design) RMIT

graduating 2007

0408 36 17 65

luca@belu.com.au

## Awards and Experience

- 2003 & 2004 Youth Artist of the Year for the City of Brimbank and Rotary Victoria  
Two Consecutive years
- 2003 Obtained an VCE Enter of 99.50 with a Premier's Award in Australian History
- 2004 Recipient of the Commonwealth Government Australian Students prize  
Ranked in the top 200 students in the country for 2003
- 2004 Winner of Melbourne Fringe Festival "Fringe Inventions"
- 2004 Exhibited at Melbourne Museum as part of the VCE Top Designs program  
Invited to give a lecture at Melbourne Museum on my designs
- 2005 Exhibited at Melbourne Museum as part of Fringe Furniture
- 2005 Established Belu Solutions - Web Design and Graphics - Creative Director
- 2005 & 2006 Shortlisted RMIT business plan competition - Two consecutive years
- 2006 & 2007 Committee member and backstage manager for AGIDEAS design conference
- 2007 Nominated for Sony Young Talent Award for Tropfest 07  
for previsualisation work on the shortlisted film "The Grey Cloud"

## Core Skills

- Visualisation Manual Sketching, Storyboarding, Model Making, High Quality Rendering and Animation
- 3d modelling Solidworks, 3d Studio Max and Rhino 3d
- 2d Software Adobe Photoshop, Illustrator and Indesign  
Both on screen presentation and print
- Interaction Extensive Web Design Knowledge and expereince (html, css, php)
- Presentation Confident, high quality presentation skills including talks at Melbourne Museum, RMIT and to VCE high school design students.



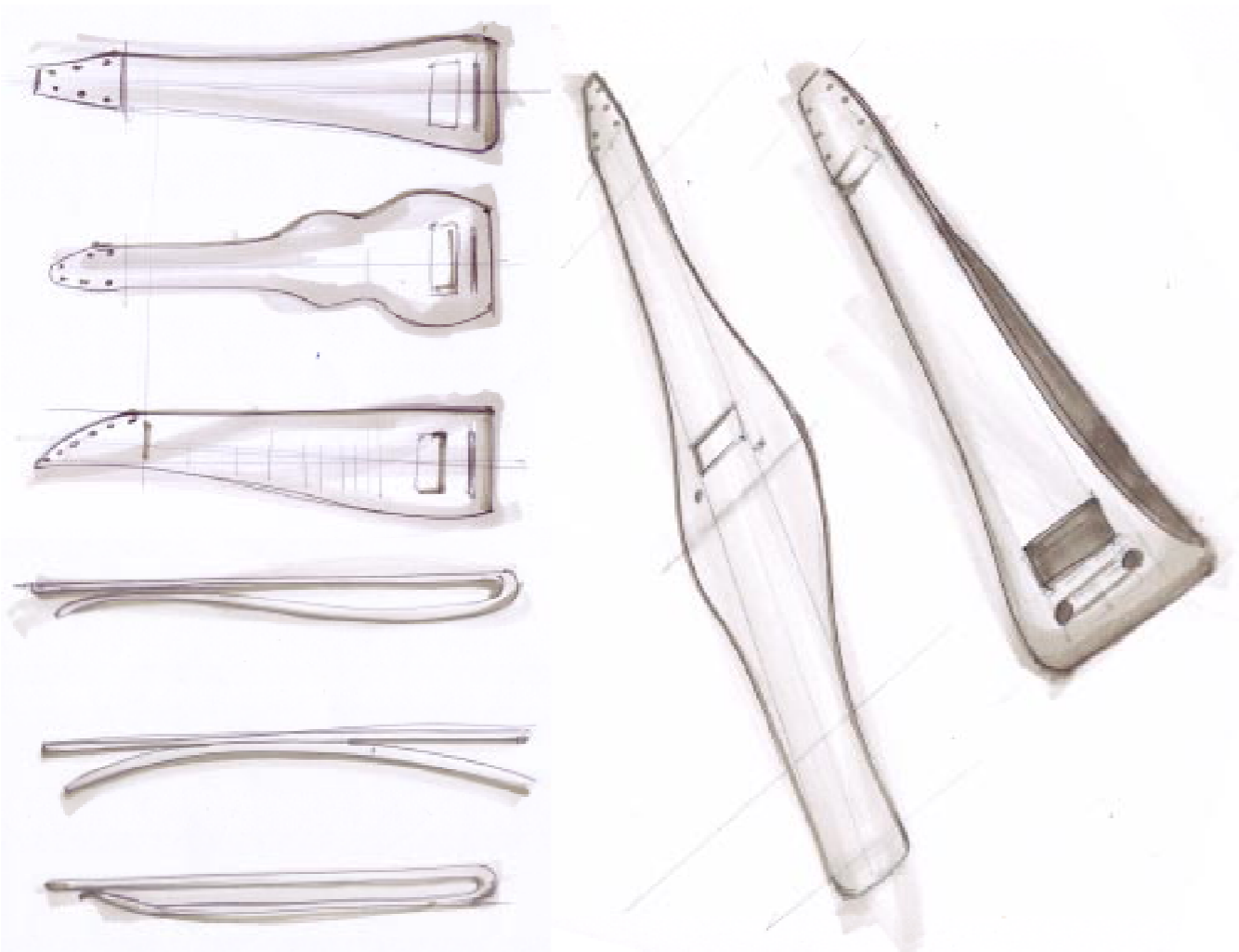

# Polyslide

acrylic lap steel guitar

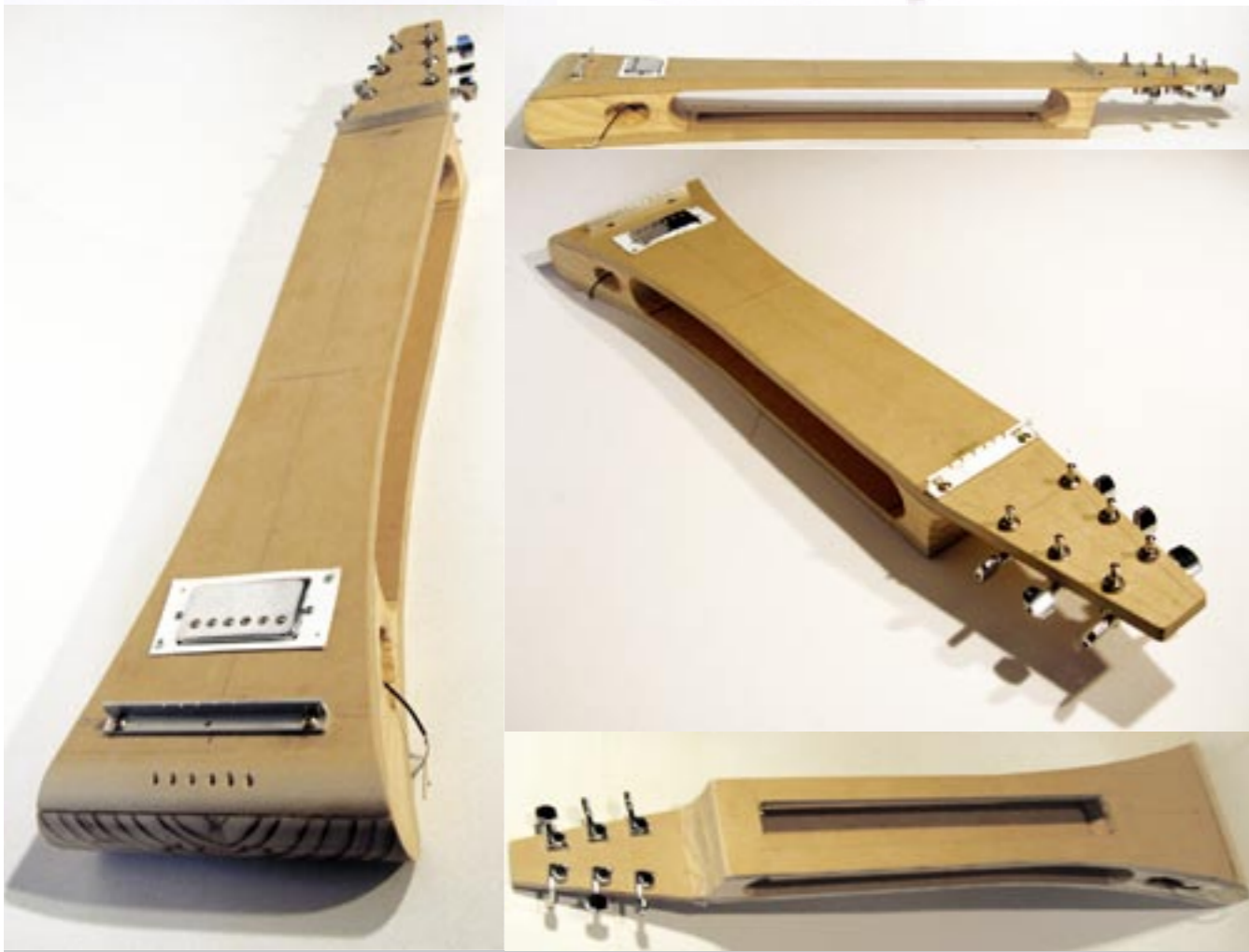
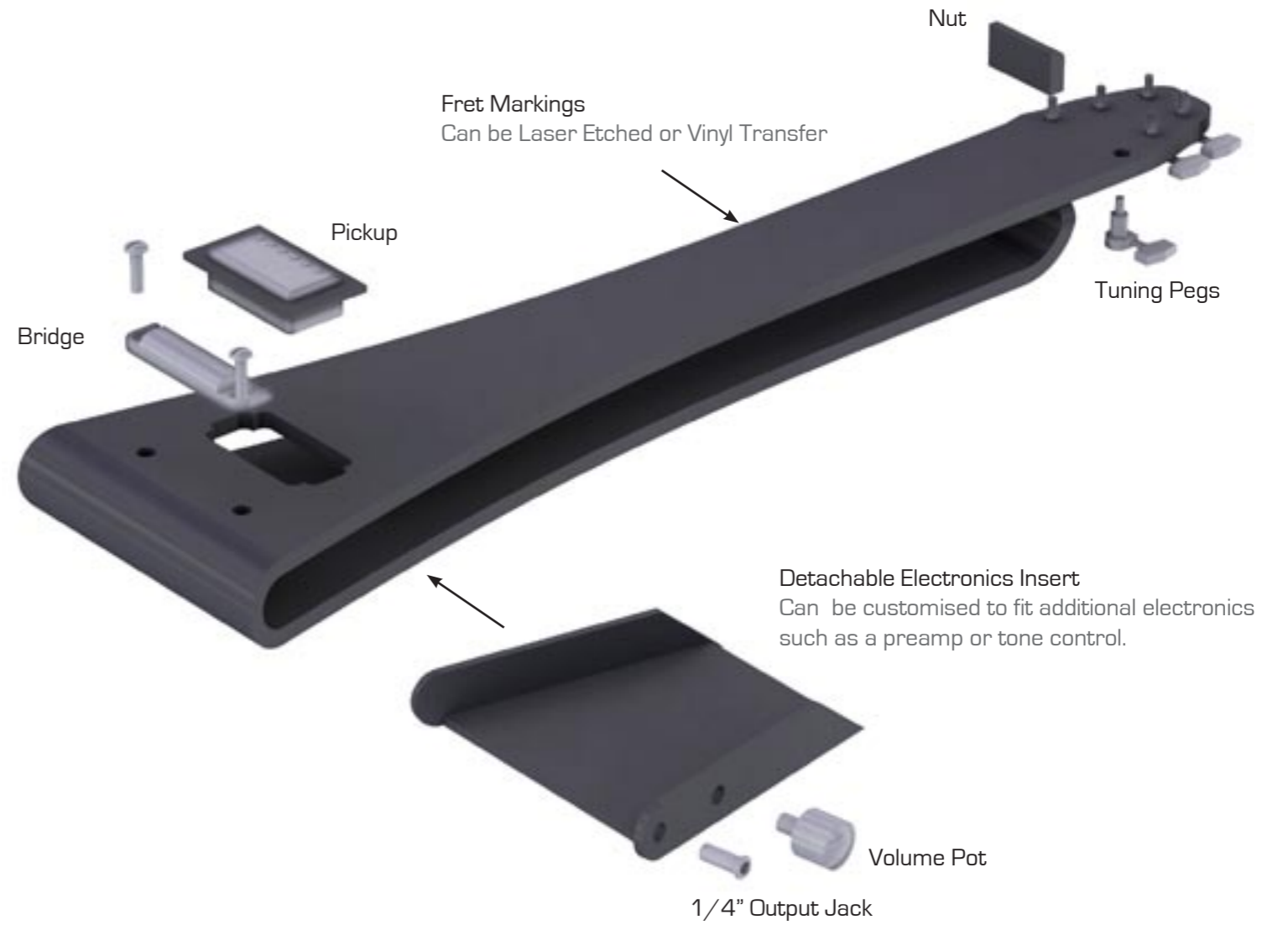

# Polyslide

acrylic lap steel guitar

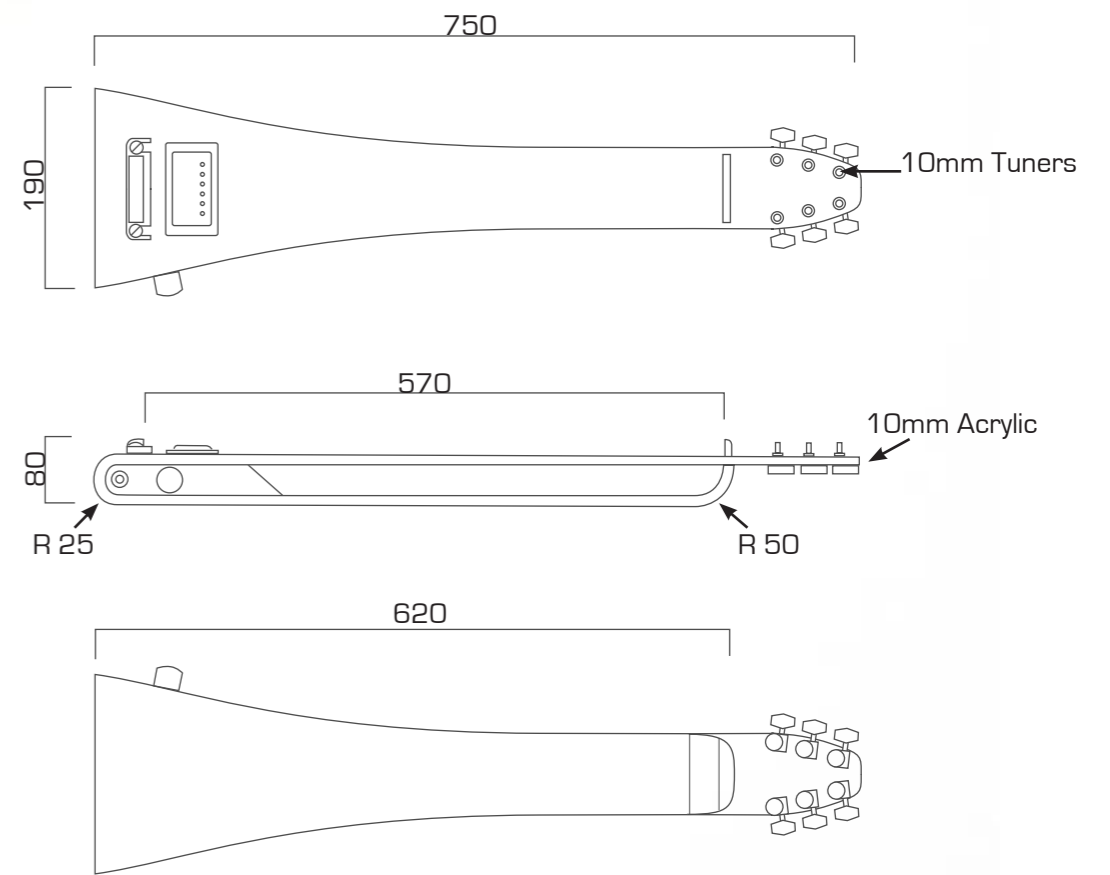



Work within a "thin client" Network



Removable plate to access cables

Versatile Mounting System  
(roof or floor)



Run worksurface off a  
mounted CPU





## What is **worksurface**

Imagine if all the physical clutter of the workspace could be brought together into one device.

**worksurface** integrates the personal computer with the physical work surface.

Many products such as the phone, fax and filing cabinet are now virtual and only appear when needed by the user and accessed via the intuitive touchscreen surface.



Move between the **physical** and the **virtual**  
let your **worksurface** transform to suit your needs



Initial Cardboard Mockup

# Stack

Portable Asian Meals Set

The moulded plastic components interlock for portability, are cheap to produce and easy to clean. The concept can be scaled down for a single place setting or multiple sets can be stacked together.



A Meal Setting for Two:

1. Main Bowl with chopstick rest
2. Rice Bowl
3. Side Plate
4. Drinking Cup
5. Chopsticks

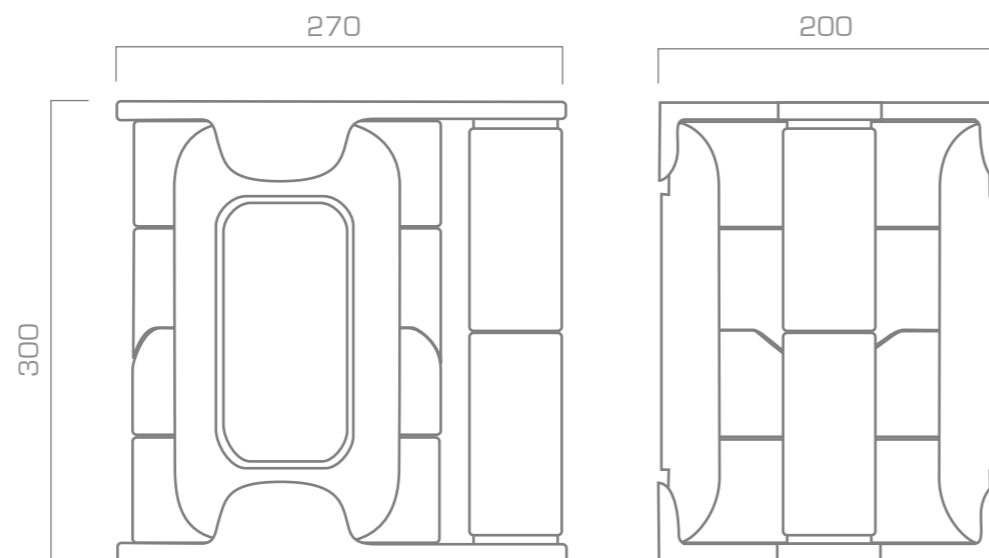

# MILKY WAY

An interactive lighting experience @ the Fed Square Atrium

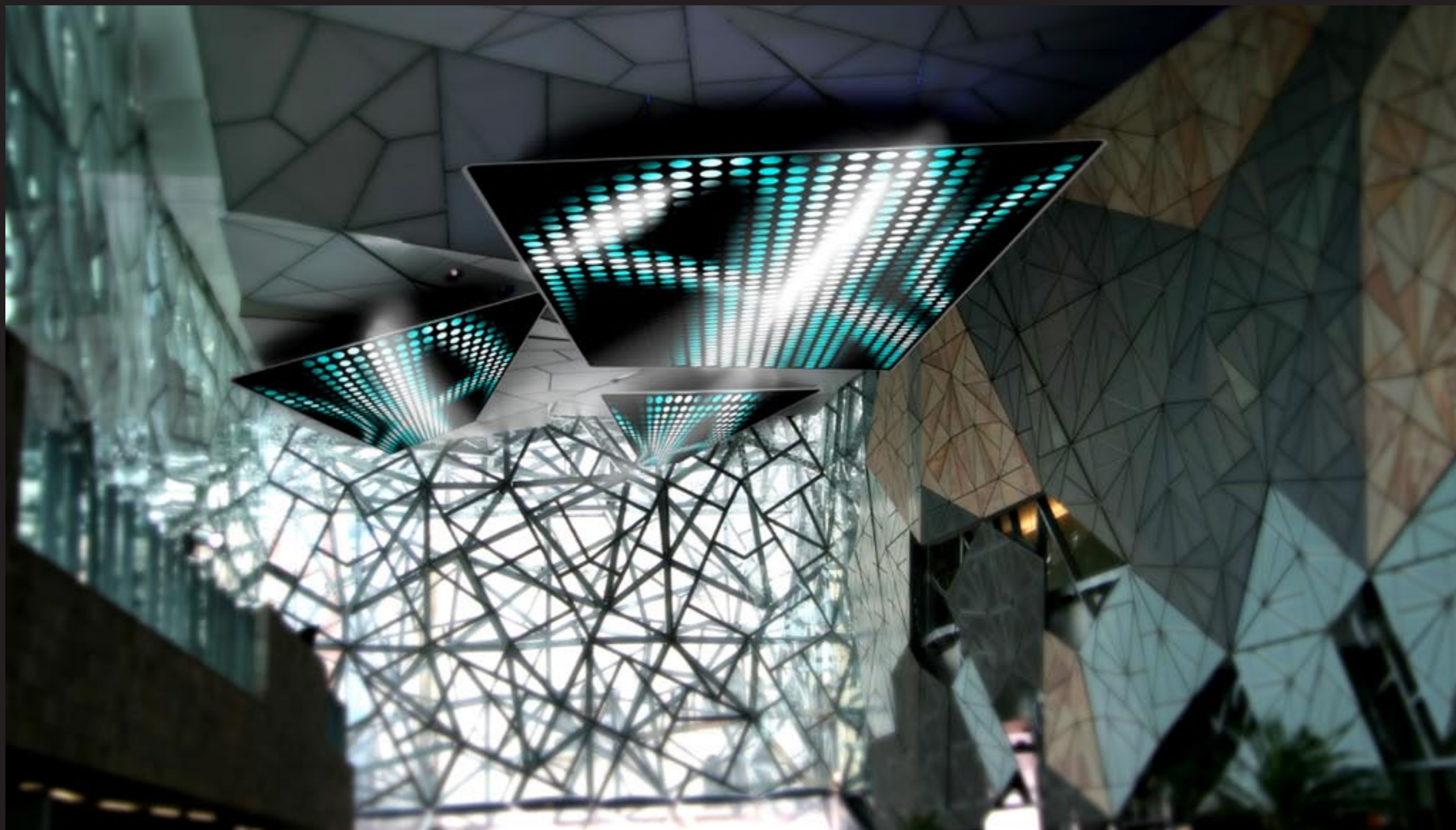

# MILKY WAY

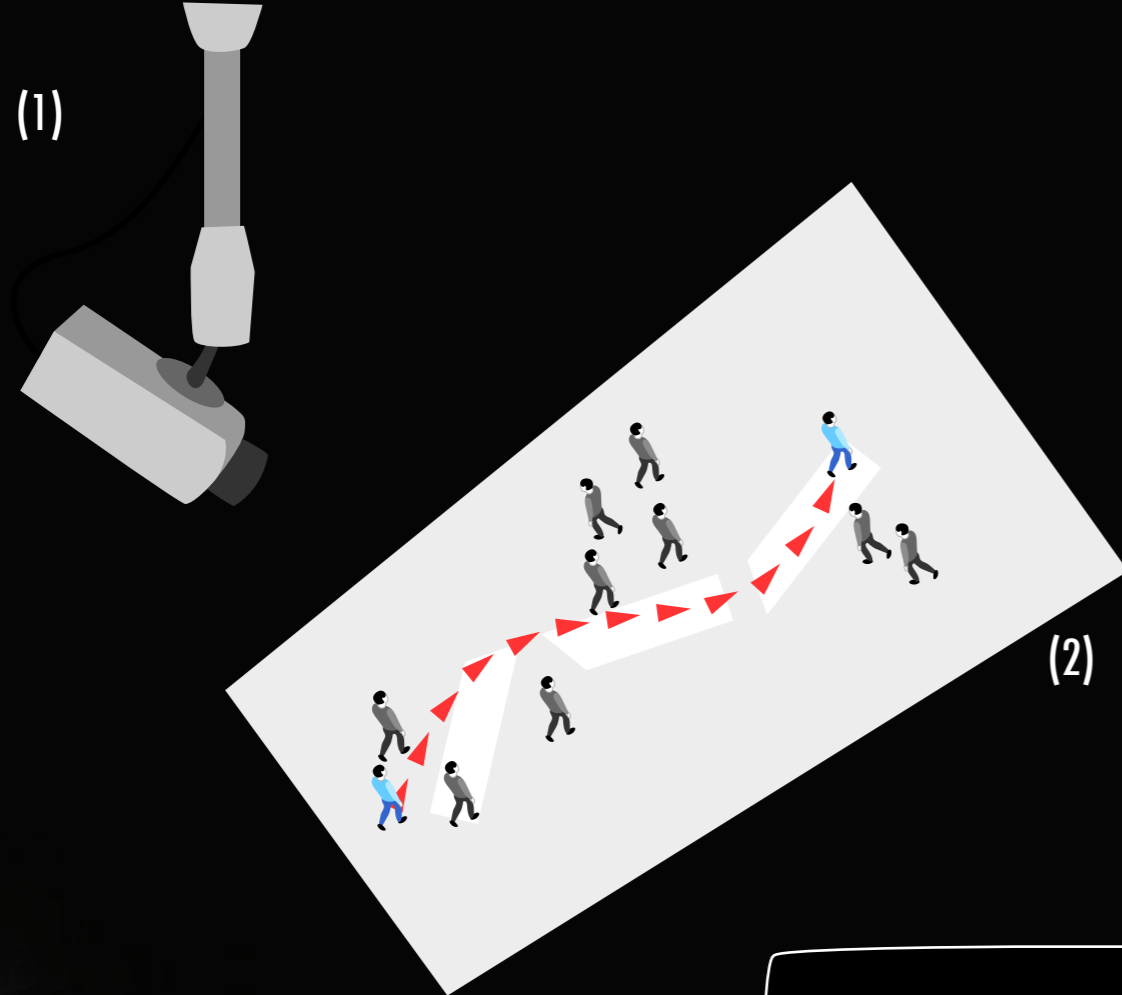

## WHAT IS IT ABOUT?

Milky Way is an innovative lighting installation created for the Atrium @ Fed Square.

Using readily available technology the ground breaking design puts visitors to the atrium in control of their lighting experience.

## HOW DOES IT WORK?

A motion tracking camera (1) follows a visitor's movement (2) as they walk through the atrium. The 2d movement pattern (3) is then quickly processed and translated into a unique graphic lighting display on the large format led panels (4) arranged on a scaffold that has been mounted to the atrium roof.

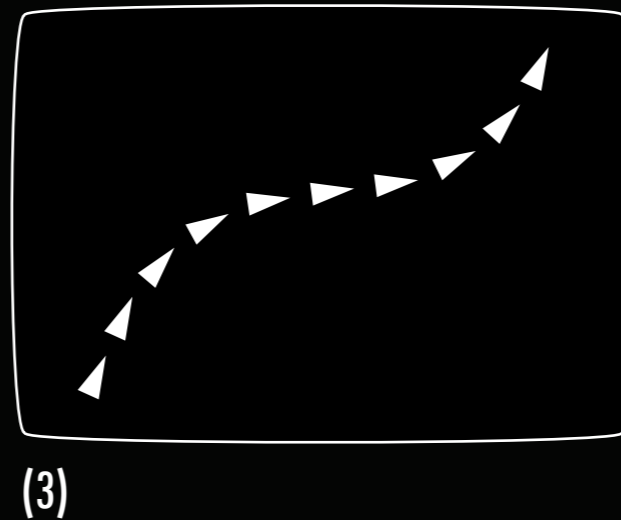

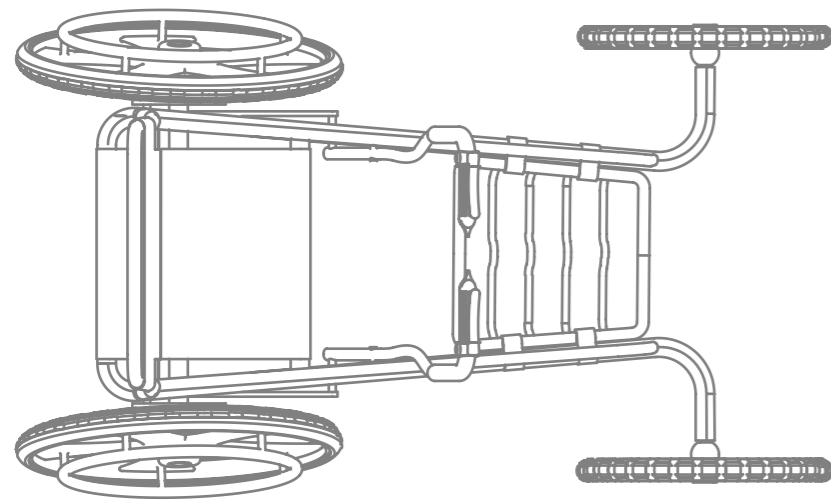
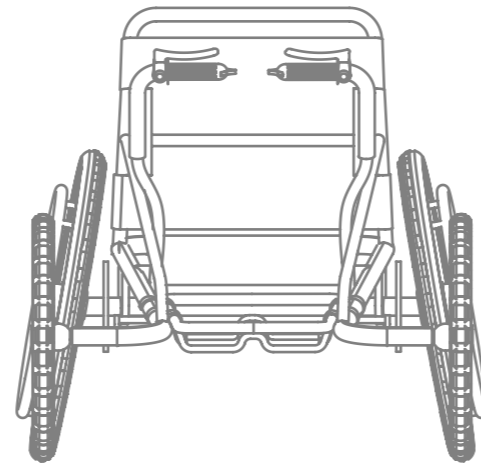
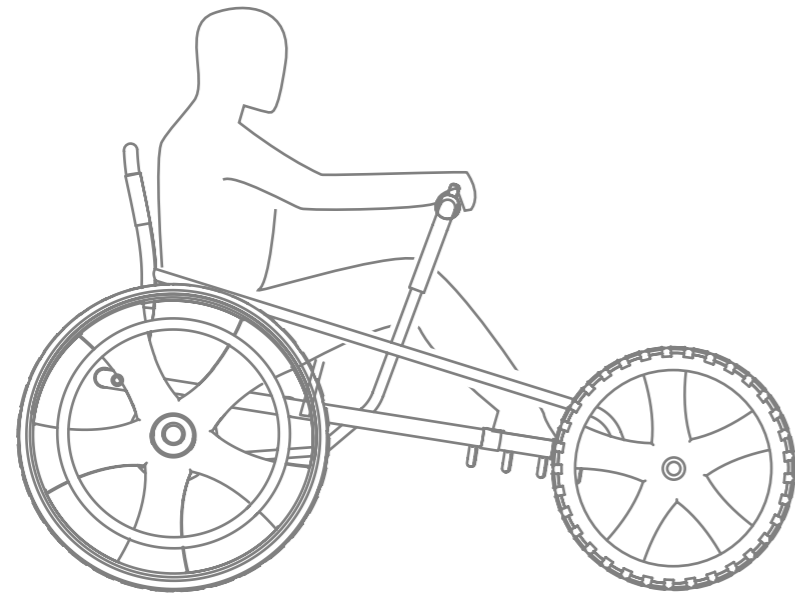

The goal was to design a Human Powered Vehicle for disabled athletes that facilitates those with limited or no lower body movement to experience offroad extreme sport.

ACCESS achieves this through lightweight construction, integration of high quality components and a range of movement options available to the user. In addition to traditional wheelchair movement via the back rims the rider can also propel forward via integrated rowing arms that drive a free wheel.

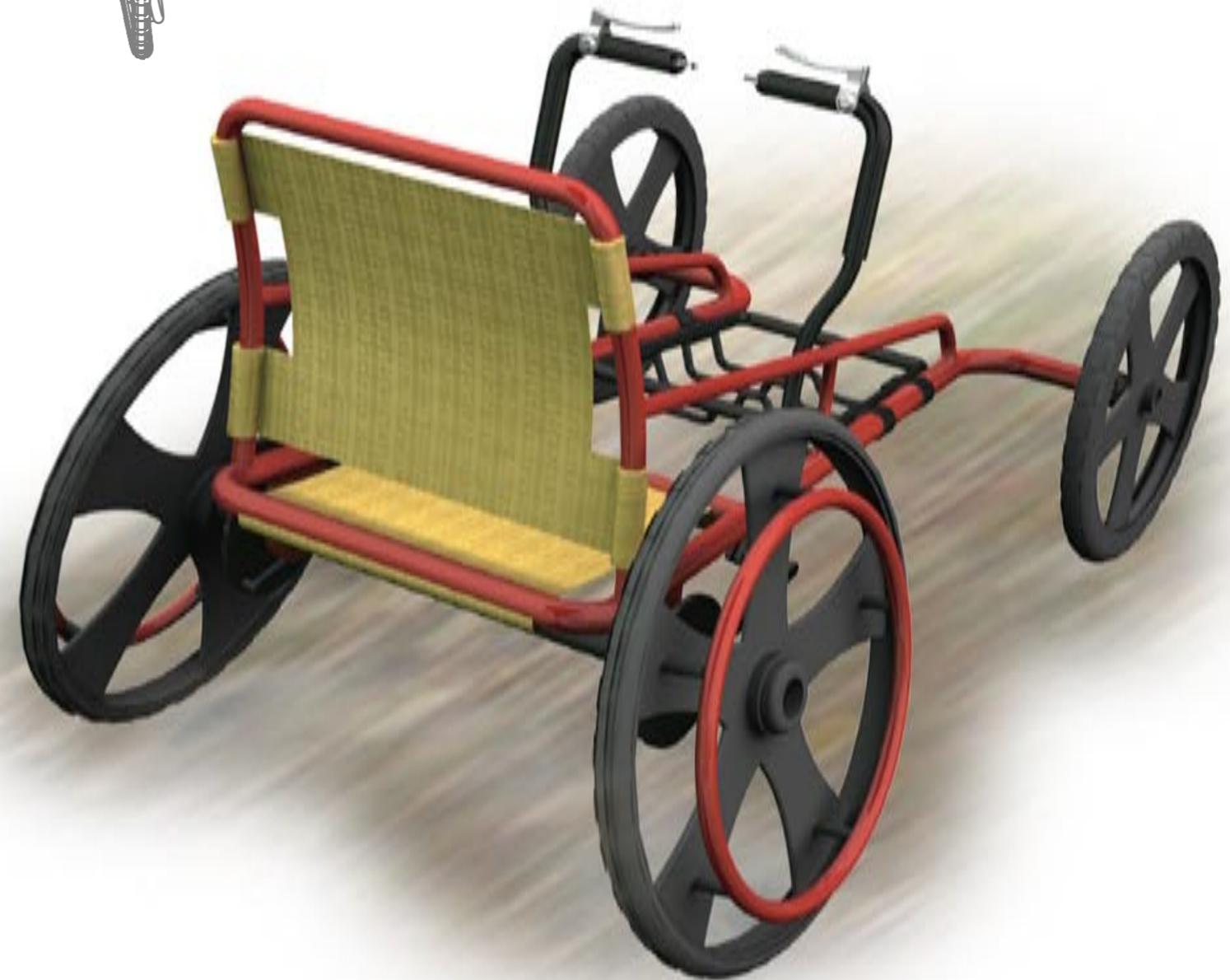

**ACCESS**  
*OffRoad Wheelchair*



**Access** - Offroad Wheelchair - 2005 LUCA ABATE